

V.G. Krasilenko¹
V. M. Kychak²
A.I. Nikolsky²
A.A. Lazarev²
D.V. Nikitovich²

SIMULATION OF ALGORITHMS FOR DETECTION, LOCALIZATION AND TRACKING OF MOVING OBJECTS IN VIDEO STREAMS

¹Vinnitsa National Agrarian University, Vinnitsa, 21021, Ukraine; krasvg@i.ua;

²Vinnitsa National Technical University, Ukraine.

Анотація. У цій роботі пропонуються та моделюються алгоритми виявлення, локалізації та відстеження рухомих об'єктів у потоці відео-кадрів. Алгоритми базуються на нелінійних нормалізованих моделях еквівалентності як міри близькості шаблону та поточного фрагмента відео - рамки, а також деяких типів операцій на сусідніх кадрах. Представлені результати моделювання запропонованих алгоритмів у Mathcad та LabView. Використання моделей еквівалентності, заходів та функцій різниці кадрів дає хороші результати розпізнавання та відстеження рухомих об'єктів.

Ключові слова: Моделювання, відеопотік, розпізнавання шаблонів, виявлення об'єктів, відстеження, модель нелінійної еквівалентності, віднімання кадрів, розпізнавання космічного інваріанту.

Abstract. In this work, algorithms for detecting, localizing and tracking moving objects in a stream of video frames are proposed and modeled. The algorithms are based on nonlinear normalized equivalence models, as a measure of the proximity of the template and the current fragment of the video frame, as well as some types of operations on neighboring frames. The results of modeling the proposed algorithms in Mathcad and Labview are presented. The use of equivalence models, measures and frame difference functions gives good results in recognizing and tracking moving objects.

Keywords: simulation, video stream, pattern recognition, object detecting, tracking, nonlinear equivalence model, subtraction of frames, space-invariant recognition, Mathcad, Labview.

Introduction.

To design and create improved biometric systems, identification systems, extreme-correlation guidance systems, neuro-cyber-machine vision and other practical applications, it is necessary to solve the problems of effective recognition of objects in images and scenes, in video frames, as well as the problems of detecting, localizing and identifying moving objects. There are many known methods and means for solving these problems [1, 2]. But the basis of most known methods and algorithms is the comparison of two different images of the same object or its fragment, or two images, one of which is a template or its transformed image, and the second image is one of a set of images belonging to different objects or classes. and only some of them belong to the class represented by this pattern. The discriminant measure of the mutual alignment of the template and the current, coordinately shifted, fragment of the analyzed image is often a mutual two-dimensional correlation function. In work [3] it was shown that when there is a strong correlation of noisy images of objects from different classes, in order to increase accuracy and other measures, probabilistic indicators, it is desirable to use image matching methods based on mutual two-dimensional equivalence spatial functions, nonlinear transformations and adaptive-correlation weighting. At the same time, there is an acute problem of recognizing not only static, but also moving objects, their tracking, i.e. tracking. In addition, in real systems, the need for recognition arises in such unfavorable situations when a moving object is blocked by obstacles, which deteriorates the quality and accuracy of recognition characteristics, since the size of the area of coincidence between the compared template and the fragment used for recognition is reduced. Therefore, the purpose of this work is to perform a series of model experiments

in the Mathcad and other model environments necessary to test improved methods and algorithms for detecting and tracking moving objects with sufficient probability and accuracy.

Model experiments in Mathcad.

To check the accuracy of determining the coordinates of the desired image, especially when recognizing moving objects, in our modeling we used splitting the processed video file into separate frames and their subsequent intra-frame and inter-frame processing. In addition, we carried out a mutual comparison of the two groups of methods used by us for detecting objects in the current frame using the corresponding template. One group of methods included processing the current image frame and a reference template image in order to search for a fragment similar to it in the frame. The second group included the formation of frames equal to the mutual differences of frames adjacent in time, and their further processing in order to detect objects of attention by comparing and combining the template and the fragment most similar to it in the difference frame. In addition, for both groups of methods, the first approach was to search for equivalence functions between the object of attention selected for study and the current fragments of the frame image by processing halftone images. The second approach differed from the first in that the resulting equivalence function is calculated by weighing all eight equivalence functions from the corresponding bit-slice representations of the template and fragment being compared. And the latter are obtained from raster images processed in each frame by pixel-by-pixel analog-to-digital conversion. In both cases, equivalently adaptive nonlinear weighting is additionally used, which enhances the discrimination of the measure used and allows for better identification of extrema (peaks) of two-dimensional spatial functions. Experiments have shown that the best of these options is available by combining equivalent differences comparing the current frame with the selected position from these fragment differences representing objects of attention. In Fig. Figure 1 shows the simulation results. For both groups, the second method of processing a sequential-slice combination gives the best results, and for moving objects that disappear when they move behind obstacles, recognition of the second group is based on the formation of current frame images of inter-frame difference images (see Fig. 1, second image from the right in top row).

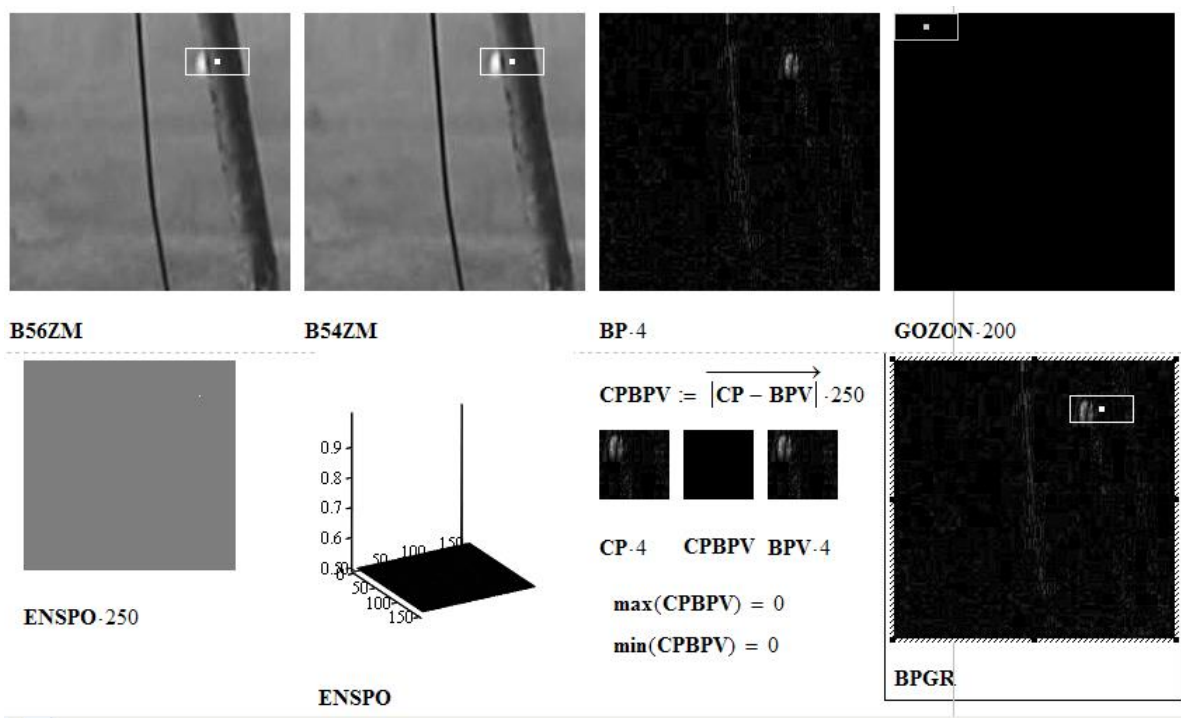

Figure 1. Model experiments in Mathcad

Experimental research of tracking algorithm of moving objects.

Usually tracking algorithms consist of such successive steps: selection and allocation of descriptors, their comparison and classification. At the comparison, a frame fragment, the descriptor of which is the most similar to the descriptor of the tracked object, is searched. When the corresponding

fragment is found, then the found object is classified. When analyzing moving objects, recorded by digital video camera using tracking algorithms, a large number of frames must be processed in the images stream. Counting the number of selected objects in each frame and grouping and clustering by different parameters, including shape, speed, location, etc., are important subtasks. And although each of these subtasks has its own specific image processing algorithms, there is an urgent need to adapt these subtasks to changing specific conditions and to ensure the possibility of their repeated repetition. And this is possible by creating a flexible, easily customizable, unified integrated tool environment. There are well-established approaches to recognition of very noisy and correlated single objects [4-11] and sets of multiple objects [5, 8, 9], including moving ones [10], with simultaneous division into clusters [5, 6, 11]. However, they are all very diverse and poorly integrated into single, flexible and configurable, and adaptive system or program. Therefore, when choosing a tool for research, we settled on Labview as the most powerful hardware system-design platform and development and development environment created in the graphical programming language «G» company National Instruments (USA). Harnessing the power of Labview and its basic applications and modules makes it relatively quickly design the required system of recognition and support, to quickly change the behavior, structure and model of the system or process, write, read and analyze video file (AVI) frames, which significantly simplifies the process of verification of developed systems -specific features and statistics. At the same time for in-depth mathematical formalism and describe some of the important stage process, for example, such as the construction of two-dimensional functions of criteria we use Mathcad, which as the results of our previous studies, there is a powerful tool. We have developed a number of possible projects detection and tracking of moving objects (DTMO). Subject to the restrictions consider DTMO one embodiment shown in Figure 2 shows a block diagram of a project, and fragments 1b shows the basic design.

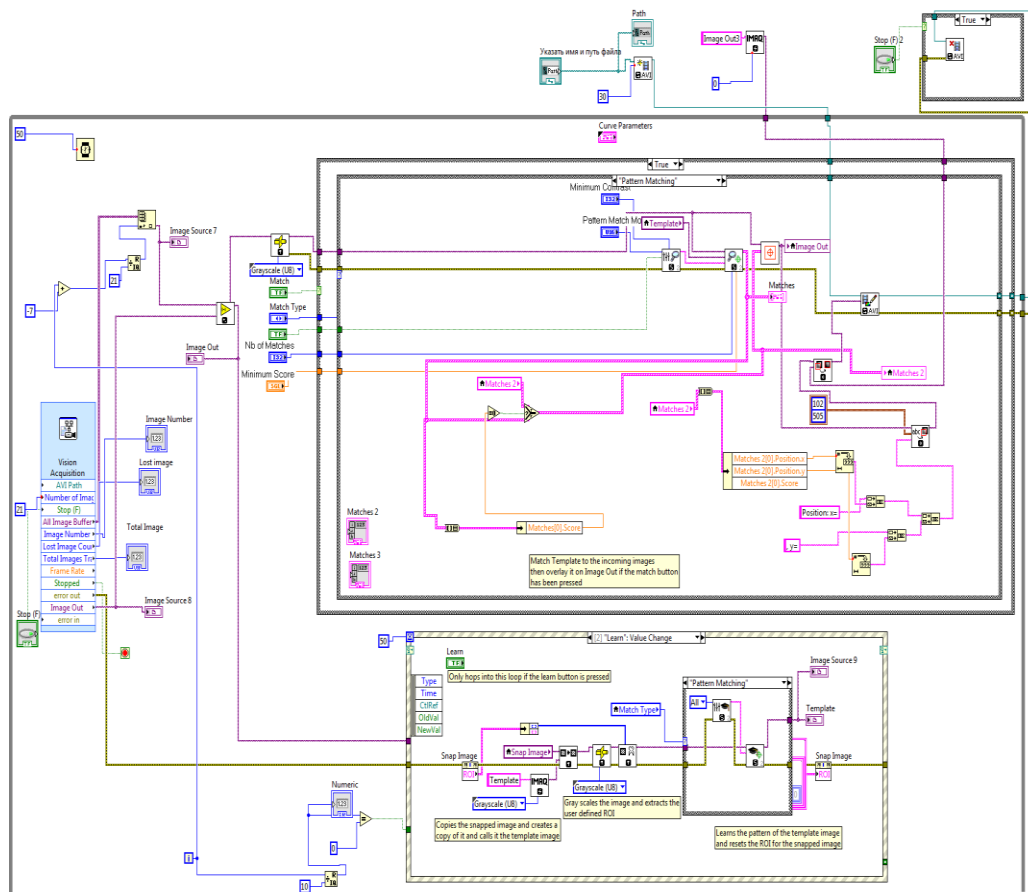

Figure2. Block diagram of the project

The system introduced by the node read AVI-files to generate both the original video stream and video stream of difference frames with the possibility of setting a different delay time (in frames) between the deductible frames. Knot formation pattern from the selected frame and the node template

comparison with selected fragments of the current frame chosen standard, but, as will be shown below, also require improvement. Results of the first experiment in support of a moving car for scenes with overlapping objects obstacles is shown in Figure 3a shows one of the frames from which was isolated and formed pattern, see Figure 3b. Some frames with dedicated red markers (frame) and the designator shown in Figure 3c. This test uses frames of the original file without pre-processing, the size of RGB-image frames - 281×126 resolution 8bit pattern 44×24 , and for comparison with the current template frame mode is used «Grayscale», so use a special type of converters, and image formats. To determine the quality of support was estimated number of frames with markers in a video, which was recorded as the video output of the project and who was using the application Vision Acquisition transformed into a set of 256 frames. Number of frames, in which a moving object (MO), was placed fully, equal to 135. Therefore, the proportion of frames in which the object is not specified, was $(135-88) / 135$, which corresponds to approximately 35%. And this in the case, where large relative to MO barrier to not.

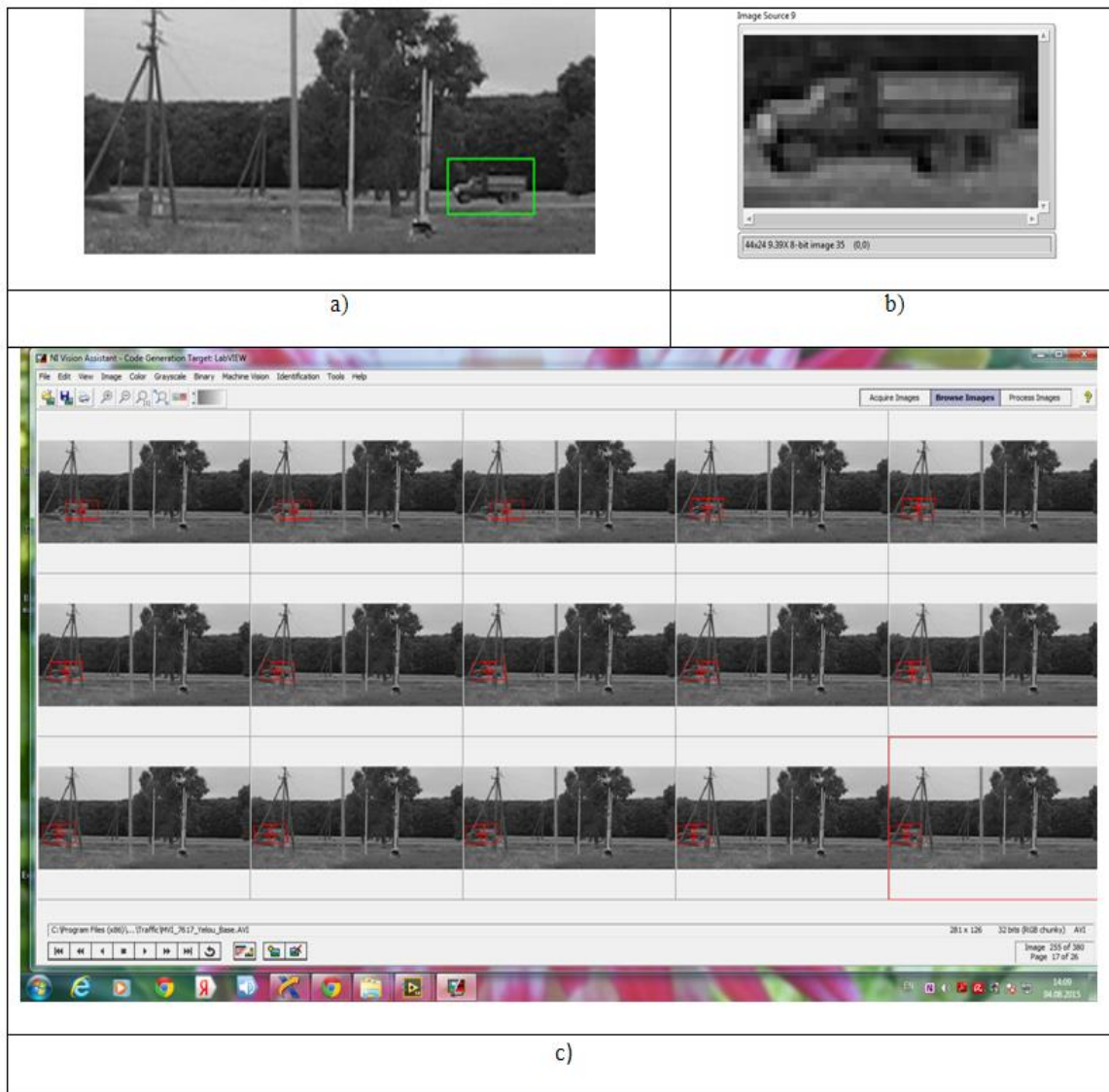

Figure 3. Modeling results: a) -- One of the original frames; b) - Template; c) - Set of frames with markers and pointers of a moving object

In this regard, we conducted a second experiment in which watched from the source to the video has been formed from the difference inter-frame video images. Number of frames for which delayed video stream varied between 3 to 7 and more. Figure 4 shows the results of simulation where the difference frames formed by delaying them in frame 7 as an absolute difference of pixel intensities. The experiment showed that the percentage of frames without reference to the MO, i.e. with the loss of

support, depends on the delay time for the inter-frame subtraction, the size of the object, since the difference pattern increases with the delay, the speed of movement relative to the frame rate and shooting conditions, and also on the specific nature scenes. For example, the camera shake when shooting hand-forms on the difference frames the contours of objects (trees, poles, etc.). In addition, the quality of the support and influence the choice of the template when a template can be selected only some (front, rear) part of the total difference pattern 4b. This experiment showed that for the most optimal video there is a delay of 7 shots, but winning over the first experiment, as there is practically no maintenance. Therefore, an additional check, we tried to work with a video file of larger dimensions (416×125 8bit image) and other shooting conditions. The results for this case are shown in Figure 5. The experiment with the file showed that the quality of support has improved and the proportion of lost bindings decreased to 15% (268 frames in all, 228 with the correct reference, 40 frames in the search mode or a loss of MO to). Thus this and similar experiments, we show that the use of inter-frame subtraction positively affect the quality and support to at least two or three times, but for special occasions, reduces the proportion of errors.

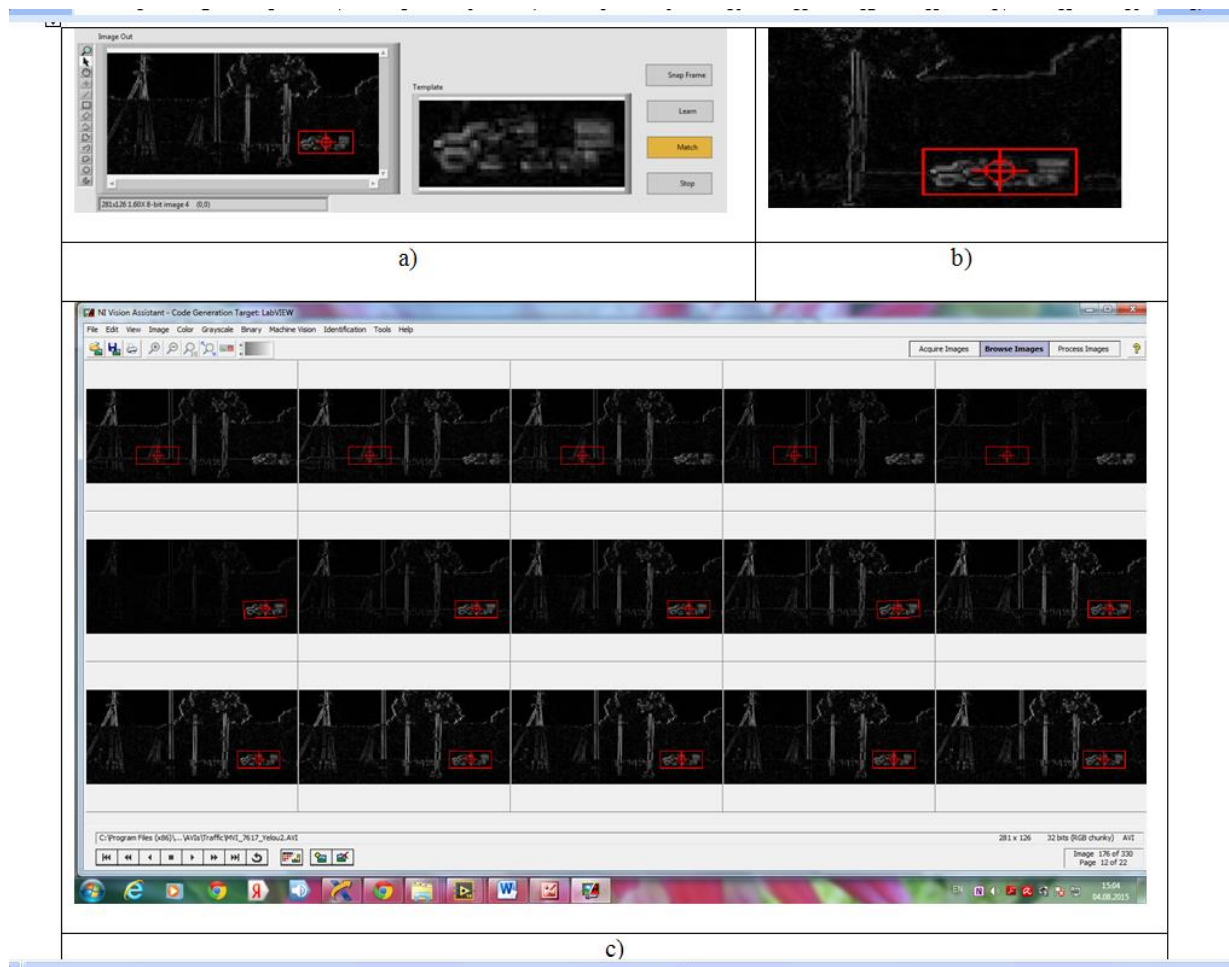

Figure 4. a) - Difference frame with selected object (left) and a pattern (right); b) - The enlarged area of selected object (difference); c) - Frames with selected object and with loss of the object.

Fourth, our experiment was to check the quality of the project in which we used a dynamic template and the results of which are shown. This experiment showed that such an approach has its advantages and disadvantages, but significant gain compared with the previous experiment does not (error rate was 15%). Further studies are needed.

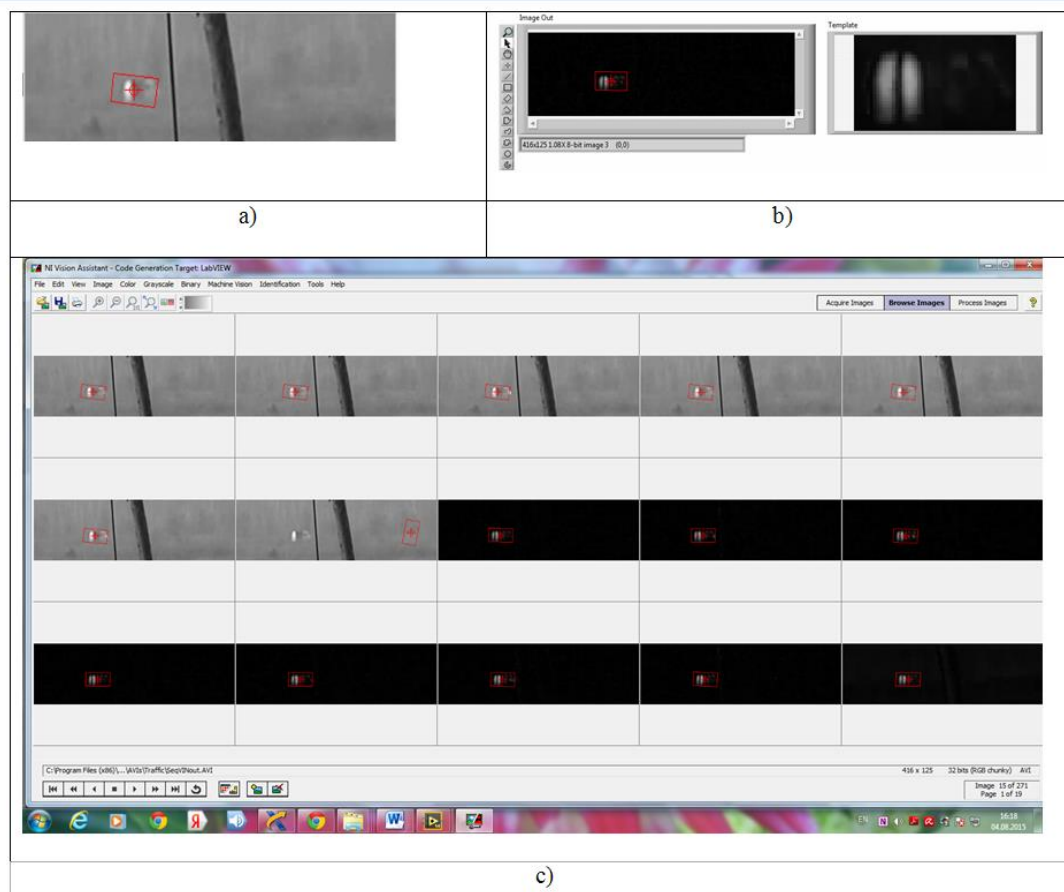

Figure 5. Modeling results: a) -- One of the original frames; b) - One difference from the frame array; c – A set of frames (the original seven and the remaining difference)

Conclusions.

Experiments in Mathcad have shown that the best option is the use of bit-map image processing and non-linear equivalence functions to align positioned comparing fragments of the difference current frame with the reference difference fragment representing the object of attention. The proposed tracking method implemented in the Labview- project, which allowed them to effectively carry out the simulation. Five different experiments with video-file showed, that application of equivalently image functions and difference frames gives good results combining recognition and consideration of moving objects in video and allows using image momentum features, set point and target designation follow this object.

References

1. Vladimir G. Krasilenko, Alexander I. Nikolsky, Alexandr V. Zaitsev, Victor M. Voloshin, "Optical pattern recognition algorithms on neural-logic equivalent models and demonstration of their prospects and possible implementations", Proceedings of SPIE Vol. 4387 (SPIE, Bellingham, WA 2001), pp.247-260.
2. Krasilenko, V. G., Recognition algorithms of multilevel images of multicharacter identification objects based on nonlinear equivalent metrics and analysis of experimental data / V. G. Krasilenko, A. I. Nikolsky, Yu. A. Boznyiak // Управляющие системы и машины. - 2013. - № 4. - С. 12-19.
3. Vladimir.G. Krasilenko, Modelling and comparative analysis of correlation and mutual alignment equivalence functions, /V.G.Krasilenko, Y.A. Boznyiak, G.N. Berozov. Science and learning process: scientific and methodical. Proceedings of VSEI Entrepreneurship University "Ukraine". - Vinnitsa: Vinnitsa Social Economy Institute of University "Ukraine", 2009. - P. 68-70.
4. Krasilenko V.G. Using a multi-port architecture of neural-net associative memory based on the equivalency paradigm for parallel cluster image analysis and self-learning // V.G. Krasilenko, A.A. Lazarev, S.K. Grabovlyak, D.V. Nikitovich. - Proceedings of SPIE Vol. 8662 (SPIE, Bellingham, WA 2013) 86620S
5. Krasilenko V.G. Experimental research of methods for clustering and selecting image fragments using spatial invariant equivalent models // V.G. Krasilenko, S.K. Grabovlyak, D.V. Nikitovich. – Proceedings of SPIE Vol. 9286, 2014

6. Krasilenko V.G. Researching of clustering methods for selecting and grouping similar patches using two-dimensional nonlinear space-invariant models and functions of normalized "equivalence" / V.G. Krasilenko, D.V. Nikitovich // VII Ukrainian-Polish scientific SPC "Electronics and information technologies" (ELIT-2015). – Lviv., 2015. – P. 129-134

7. V. G. Krasilenko, A. I. Nikolsky, and J. A. Flavitskaya „The Structures of Optical Neural Nets Based on New Matrix_Tensor Equivalently Models (MTEMs) and Results of Modeling” ISSN 1060_992X, Optical Memory and Neural Networks (Information Optics), Vol. 19, No. 1, © Allerton Press, Inc., pp. 31–38, 2010.

8. Krasilenko, V.G., Nikolsky, A.I., Bozniak, Y.A., "Recognition algorithms of multilevel images of multicharacter identification objects based on nonlinear equivalent metrics and analysis of experimental data" in Sensor Fusion: Architectures, Algorithms, and Applications VI, edited by Belur V. Dasarathy, Proceedings of SPIE Vol. 4731 (SPIE, Bellingham, WA 2002) pp. 154-163.

9. Krasilenko Vladimir G. "Design and simulation of a multiport neural network heteroassociative memory for optical pattern recognitions"/Vladimir G. Krasilenko, Alexander A. Lazarev, Svetlana K Grabovlyak // Proceedings of SPIE - Vol. 8398.

10. Vladimir G. Krasilenko, Aleksandr I. Nikolsky, Alexander A. Lazarev, "Modeling optical pattern recognition algorithms for object tracking based on nonlinear equivalent models and subtraction of frames", in MIPPR 2015: Pattern Recognition and Computer Vision, Tianxu Zhang; Jianguo Liu, Editors, Proceedings of SPIE Vol. 9813 (SPIE, Bellingham, WA 2015), 981302.

11. Vladimir G. Krasilenko, Alexander A. Lazarev, Diana V. Nikitovich, "Modeling and possible implementation of self-learning equivalence-convolutional neural structures for auto-encoding-decoding and clusterization of images", Proc. SPIE 10453, Third International Conference on Applications of Optics and Photonics, 104532N (22 August 2017); doi: 10.1117/12.2276313; <http://dx.doi.org/10.1117/12.2276313>

Красиленко В.Г. кандидат технічних наук, доцент, Вінницький національний аграрний університет, Вінниця, krasvg@i.ua .

Кичак В.М. доктор технічних наук, професор, Вінницький національний технічний університет, Вінниця, vmkychak@gmail.com

Нікольський О.І, кандидат технічних наук, доцент, Вінницький національний медичний університет, Вінниця, krasvg@i.ua

Лазарєв О.О., кандидат технічних наук, доцент, Вінницький національний технічний університет, Вінниця, krasvg@i.ua

Нікітович Д.В. аспірант, спеціальності 172-Телекомунікації та радіотехніка, Вінницький національний технічний університет, Вінниця, diananikitovych@gmail.com

Krasilenko V.G., candidate of technical sciences, associate professor, Vinnytsia National Agrarian University, Vinnytsia, krasvg@i.ua

Kychak V.M. doctor of technical sciences, professor, Vinnytsia National Technical University, Vinnytsia. vmkychak@gmail.com

Nikolskyi, O. I., candidate of technical sciences, associate professor, Vinnytsia National Medical University, Vinnytsia, krasvg@i.ua

Lazarev O.O., candidate of technical sciences, associate professor, Vinnytsia National Technical University, Vinnytsia, krasvg@i.ua

Nikitovych D.V, graduate student, majoring in 172-telecommunications and radio engineering, Vinnytsia National Agrarian University, Vinnytsia, diananikitovych@gmail.com.